

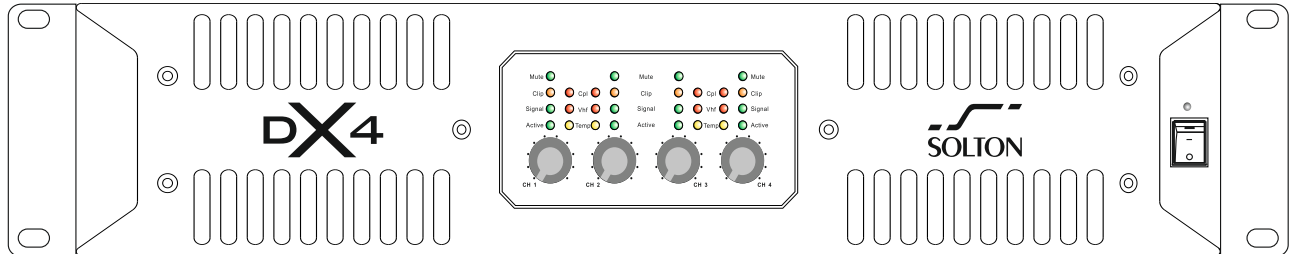

DX4

A PRODUCT OF SOLTON ACOUSTIC GERMANY



ENGLISH

Contents

Contents.....	1
Important note.....	2/3
Control elements.....	4
Rear panel features introduction	5/6
Audio input and output connections	7
Stereo Mode.....	8
Bridge Mode.....	9
Professional Power Amplifier Specifications.....	9

Important Note

WARNING NOTICES

SAFE GUARDS

Electrical energy can perform many useful functions. This unit has been engineered and manufactured to assure your personal safety .Improper use can result in potential electrical Shock or fire hazards .In order not to defeat the safeguards , observe the following precautions for its installation , use and servicing.



Explanation of Graphical Symbols



CAUTION
RISK OF ELECTRIC SHOCK
DO NOT OPEN

CAUTION
RISK OF ELECTRIC SHOCK:
OPEN ONLY IF QUALIFIED
AS SERVICE PERSONNEL

WARNING: TO PREVENT FIRE OR ELECTRIC SHOCK, DO NOT EXPOSE THIS EQUIPMENT TO RAIN OR MOISTURE.

IMPORTANT NOTE

ATTENTION: This unit must be protected from damp because of the risk of fire and the possibility of electric shocks.

1. Make sure that you have the correct mains voltage. Only operate the unit at the mains voltage marked on the rear panel.
2. Make sure that nothing especially no metal objects are inserted into the device. This could result in electric shock or malfunction.
3. If the unit is subjected to extreme fluctuations of temperature e.g. On being transported from outside into a heated room, condensation can form. The unit should not be used until it has reached room temperature.
4. In the event of water or any other fluid being accidentally spilt on the unit switch the unit off immediately and send it to a qualified service workshop for inspection.
5. Make sure that the unit is always well ventilated and never exposed to direct sunlight
6. Do not use sprays to clean the unit as they have a detrimental effect on the unit and could ignite suddenly.
7. The machine use single power switch, please cut off the power before fix.
8. Please do not put the cup, vessel of flower or container above the machine, In case the leak out water then cause the leakage current off the machine.

User responsibility

1. Mains connection grounding

 Your amplifier must be connected to a grounded socket outlet.

2. Speaker output hazard

 Power amplifiers are capable of producing hazardous output voltages. To avoid electrical shock, do not touch any exposed speaker wiring while the amplifier is operating. The external wiring connected to the speaker terminals shall be installed by a qualified instructed person or ready-made leads or cords of appropriate capacity shall be used.

 As the amplifier outputs produce high voltage, do not connect or disconnect speaker cables when the mains power is on. Also, attach the safety cover on the speaker terminals for safe operation and to comply with electrical product approvals.

3. Radio interference

This product uses radio frequency energy and if not used or installed in accordance with these operating instructions, may cause interference to other equipment, such as radio receivers. However, there is no guarantee that Interference will not occur in a particular installation. If this equipment does cause harmful interference to radio or television reception, which can be determined by turning the equipment on and off, the user is encouraged to try to correct the interference by one or more of the following measures:

- ▶ Reorient or relocate the antenna.
- ▶ Increase the separation between the equipment and receiver.
- ▶ Connect the equipment to an outlet on a circuit different from that to which the receiver is
- ▶ Check if the affected unit complies with the EMC limits for immunity, (CE-labeled). If not, address the problem with the manufacturer or supplier. All electrical products sold in the EC must be approved for immunity against electromagnetic fields, high voltage flashes, and radio interference.
- ▶ Consult the dealer or an experienced Radio/TV technician for help.

The amplifier uses a forced-air cooling system with Air flow from front to rear, maintaining a low operating temperature within defined limits.

4. Speaker damage

 Your amplifier is very powerful and can be potentially dangerous to both loudspeakers and humans alike. Many loudspeakers can be easily damaged or destroyed by overpowering them. Always check the speaker's continuous and peak power capabilities. Although the amplifier's attenuators can be used to reduce the overall gain, an increase of the input signal can result in full output power, which may cause damage to connected speakers.

5. Maintenance

For safe and reliable operation, the dust covers behind the front panel should be cleaned regularly. If the dust filters are not maintained there will be safety risks. For example the unit can ignite the dust and a fire will occur due to high internal temperatures. There is also a risk that the unit will malfunction since it is dependent on constant airflow from front to rear. If the dust filters are not clean and the unit malfunctions, any resultant problems will not be covered by the warranty.

 If you are not 100% confident of your Competence to replace the mains plug, engage Qualified personnel to do the job.

Once a suitable AC supply is connected, the amplifier can be turned on using the front panel power switch. The amplifier then goes through a soft-start sequence as it self-checks its circuits. The fans will blow at high speed before dropping to idle, and the -power LED -will illuminate.

Inrush power is controlled and limited during -softstart, enabling multiple amplifiers to be powered up Simultaneously.

Grounding

There is no ground lift switch or terminal on the amplifiers. The signal ground is always floating, via a resistor, to chassis and therefore the grounding system is automatic.

In the interests of safety, never disconnect the earth (Ground) pin on the AC power cord.

Use balanced input connections to avoid hum and Interference.

Control elements

Front panel

The front panel LED area includes the following indicators per channel:

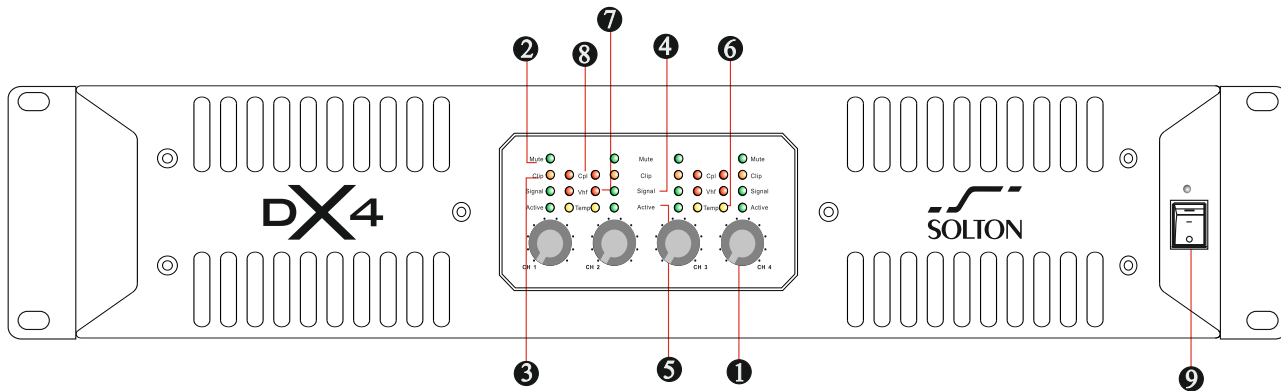

1. LEVEL CONTROL

Calibrated detente potentiometers to alter the total gain of the power amplifier . In order to avoid distortions in mixing consoles upstream , these controls should normally be positioned between 0 and 10 . The calibrated markings show the additional attenuation directly.

2.MUTE LED

MUTE - Au protection under mute position.

3.Clip/limit indicator

This indicator signals if the amplifier output is clipping or limiting. It has two different indication states:

If the Clip limiter is engaged, It has a short time constant and it illuminates briefly.

If the clip limiter is not engaged, it has an increased time constant, and it illuminates for a longer Period.

4.SIG / HI-IMP LED

Green SIGNAL Indicates output signal levels in normal operating range
Hi-Imp - High-impedance/open load detected (Orange)

5.ACLIVE LED

Thes Led lights up when the unit is powered.

6. TEMP

This LED lights up if the limiter has been activated and the power amplifier is being operated at the clip level .If the LED flashes briefly ,this is not a cause for concern. If this LED is lit permanently ,the volume should be reduced to avoid overload damages to the connected loudspeaker systems.

7.VHF

VHF-Very High Frequency protection active (output muted)(Yellow constant)

8.CPL LED

CPL - (Orange constant with output muted): Low impedance / short circuit detection fault

9.POWER Switch

Turn the unit power on or off

Rear panel features introduction

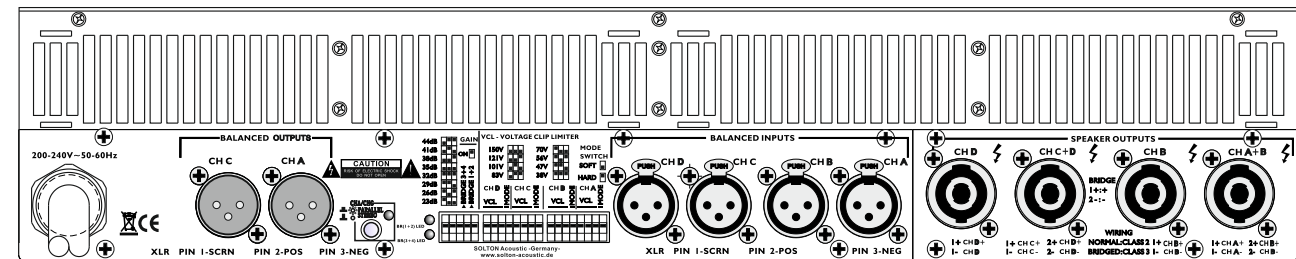
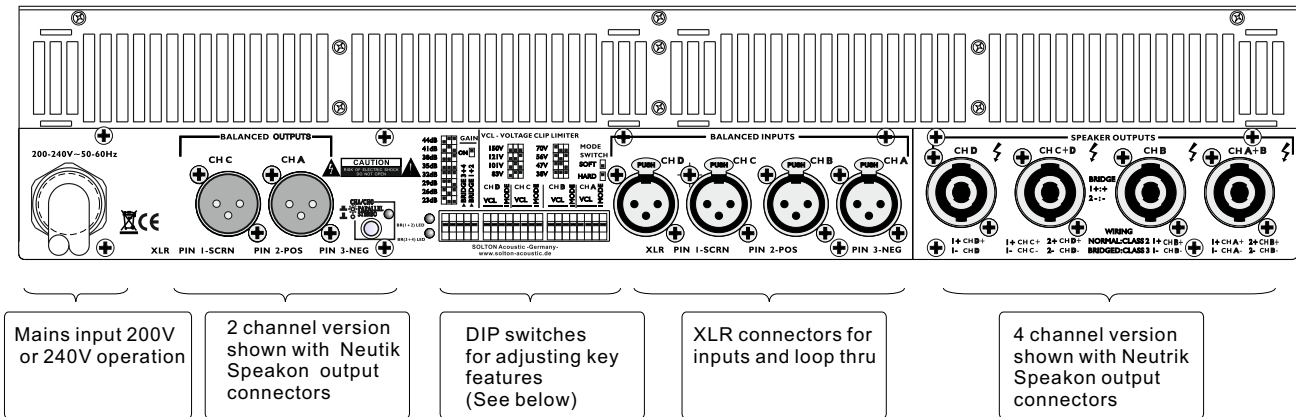

Rear view of 4-channel model fitted with Speakon connectors



Four-channel model shown. Two-channel versions have VCL and Bridge Mode switches for channels 1 and 2 only. All models have different VCL values. Functions are otherwise identical.

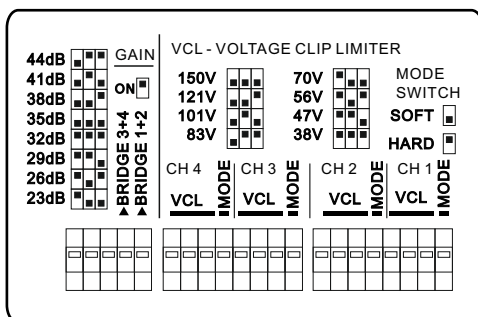

6.2.2 The DIP switch features

The following features may be adjusted using the DIP switches on the rear-panel of the amplifier. Gain - Globally set for all channels, from +23 dB to +44dB in 3 dB steps.

Bridge A+B and C+D - Switches the channel pairs into bridge mode operation. An automatic -6 dB gain compensation is applied.

VCL - VOLTAGE CLIP LIMITER

150V		70V	
121V		56V	
101V		47V	
83V		38V	

VCL - Voltage Clip Limiter adjustment is provided for eight discrete levels for each channel for each channel. Select the setting most appropriate for connected speakers.

VCL - in Bridge Mode

DX4
300V
242V
202V
166V
140V
112V
94V
76V

Mode - Select VCL mode to either Hard or Soft operation. For channels driving sub-woofers and low-frequency drivers, it is recommended to use the Hard setting for optimal operation. For mid- and high- frequency drivers, always select Soft.

Output connectors

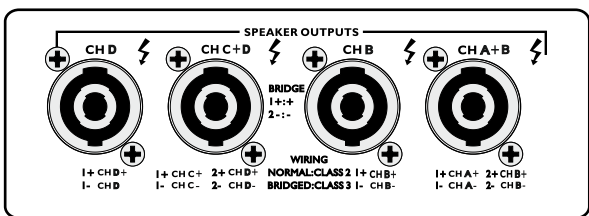

Speakon outputs - 4-channel models

Input connectors

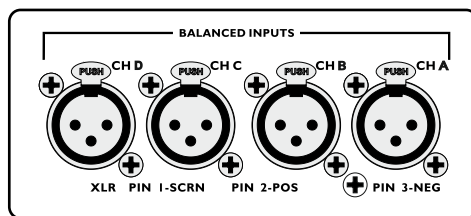

Audio inputs - 4-channel models

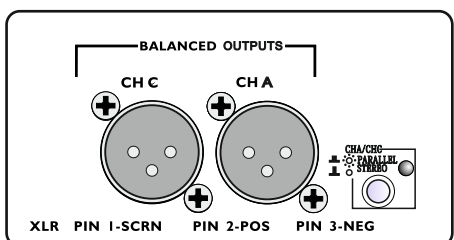

Link outputs PARALLEL or STEREO models

Link outputs PARALLEL or STEREO models:
In stereo models, the signal input into channel A can be output from channel A only, similarly, the signal input into channel A or channel C can be output from channel A and channel C.

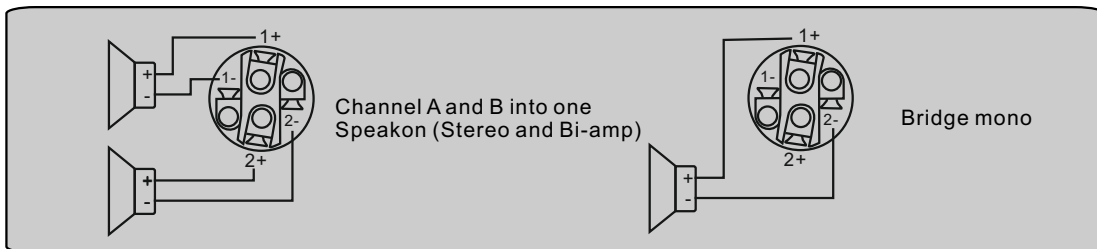

Four-channel amplifiers Additional connectors are provided for Channel C and Channel D. Channel C functions as Channel A above, and Channel D as Channel B above.

Audio input and output connections

BALANCED INPUT CONNECTIONS

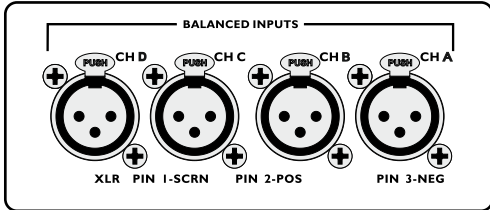

Audio inputs - 4-channel models

The XLR input connectors are electronically balanced, and wired according to the IEC 268 standard (pin 2 = hot). XLR input connectors should be wired as follows:

- Pin 1 Ground/shield
- Pin 2 Hot (+)
- Pin 3 Cold (-)

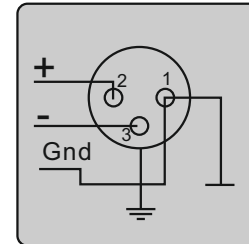

When linking the same source signal to several input channels, be aware that there is a limit to the number of channels an output source can "drive". A typical output source (e.g. a DSP crossover unit) can drive up to four amplifier channels before external line-drivers might be required to buffer the signal.

Unbalanced Input connections

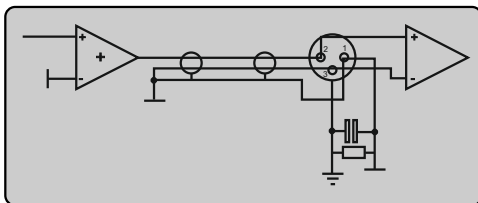

To connect an input to an unbalanced source, it is possible to connect pins 1 and 3 in the XLR plug at the amplifier end of the cable. However, a better method is to connect pin 3 to the shield at the source end of the cable, as this usually results in better hum and noise rejection. Balanced input connections are recommended whenever possible.

Speakon Output connections

Refer to the instructions in this section if your amplifier is equipped with the Speakon output connectors.

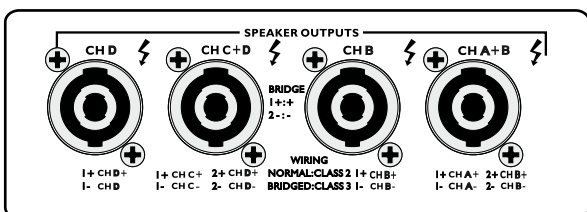

Speakon outputs - 4-channel models

Stereo Mode

Before setting the mode , please turn off the amplifier and slide the mode select switch to below (Picture 1) .In this mode, Channel A an Channel B operate independently (just traditional stereo amplifier). The signal input into channel A can be output from channel A only, similarly, the signal input into channel B can be output from channel B only. The many channels , one by one in order type pushes.

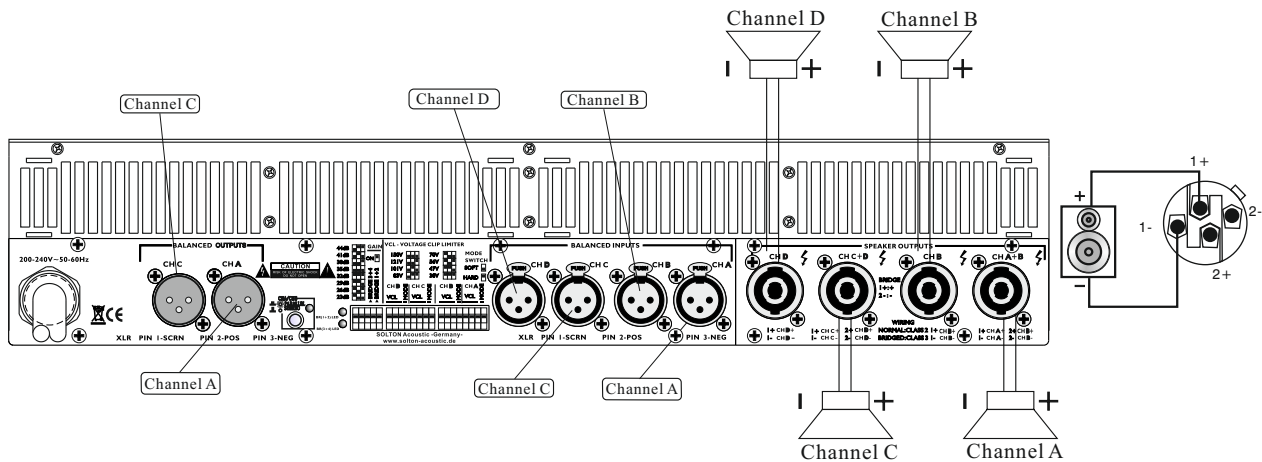
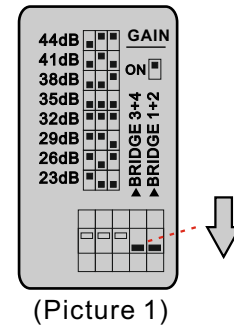

Bridge Mode

Before setting the mode , please turn off the amplifier and slide the mode select switch to above (Picture 2), channel A and channel B are bridged, channel C and channel D are bridged. At time , the signal input into channel A and channel C will be output from the bridge end. On other hand , the output level control of channel B and channel D should be turn down to smallest . Only the volume control of channel A and channel C are used to control the volume of whole

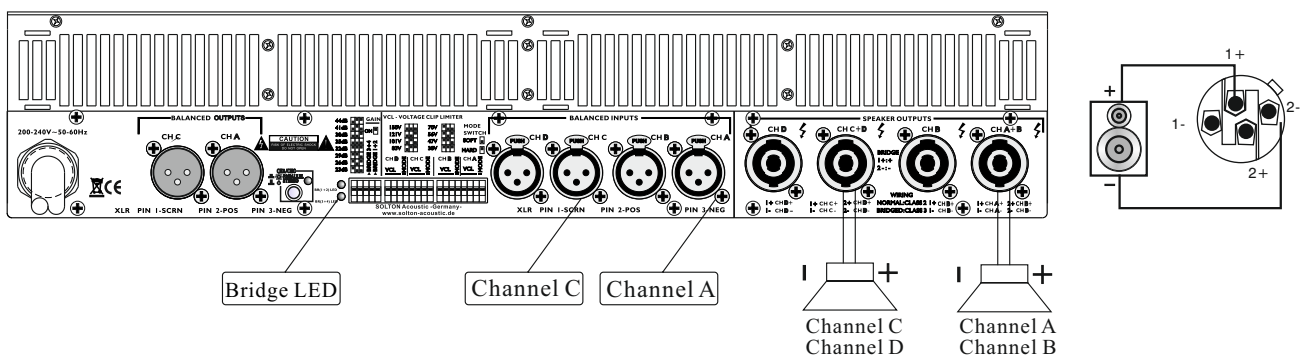
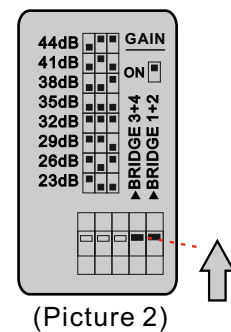

Amplifier Specifications

VOLTAGE PEAK LIMITER			OUTPUT POWER PER CHANNEL (W) LOAD			
VPL Setting	V peak	Vrms	16 Ohms	8 Ohms	4 Ohms	2 Ohms
150 V	150	106	620	1240	2485	2500
121 V	121	86	435	870	1740	2500
101 V	101	70	315	625	1250	2500
83 V	83	59	225	450	900	1805
70 V	70	49	160	315	630	1260
56 V	56	40	110	220	435	870
47 V	47	33	80	155	315	625
38 V	38	27	55	110	220	440

VOLTAGE PEAK LIMITER			OUTPUT POWER BRIDGED PER TWO CHANNELS (W) LOAD			
VPL Setting	V peak	Vrms	16 Ohms	8 Ohms	4 Ohms	2 Ohms
38 V	38 V	38 V	38 V	38 V	38 V	38 V
150 V	300 V	212 V	2485	4970	5000	n.r.
121 V	242 V	172 V	1740	3480	5000	n.r.
101 V	202 V	140 V	1250	2500	5000	n.r.
83 V	166 V	118 V	905	1810	3615	n.r.
70 V	140 V	98 V	630	1260	2520	n.r.
56 V	112 V	80 V	435	870	1740	n.r.
47 V	94 V	66 V	315	625	1250	n.r.
38 V	76 V	54 V	220	440	880	n.r.

Amplifier Specifications

Model	DX4
Output Power	
8 $\bar{7}$ Stereo Power	4 x 1300W
4 $\bar{7}$ Stereo Power	4 x 2200W
2 $\bar{7}$ Stereo Power	4 x 2500W
8 $\bar{7}$ Bridged Monon Power	2 x 4400W
4 $\bar{7}$ Bridged Monon Power	2 x 5000W
FREQUENCY RESPONSE 20Hz-25kHz \pm 0.5dB	
THD+N(Rated power,4 $\bar{7}$ /KHz)%	0.1%
Signal Noise Ration(dB)	110dB
Input Impedance	20k $\bar{7}$ Balanced /10k $\bar{7}$ Unbalanced
Output Connectors	Speakon Connectors (NEUTRIK)
Power Requirement	200-240V-50-60Hz
Dimension	
Air frame	483x377x88mm
Weight	
Weight(net)	13Kg



SOLTON Acoustic

Oberer Mühlweg 6 / 94060 Pocking, Rottau / GERMANY

Tel: +49 (0) 8531 / 913880 Fax: +49 (0) 8531 / 978507

Web: www.solton.de E-mail: info@solton-acoustic.de

All rights reserved to SOLTON Acoustic. All features and content might be changed without prior notice. Any photocopy, translation, or reproduction of part of this manual without written permission is forbidden. Copyright © 2020 SOLTON Acoustic
